

Manufacturer's Standard

ELMESS EIH Element Support Plates

In accordance with ASME Boiler and Pressure Vessel Code Section VIII, Division 1, Edition 2023

Status: 24th September 2024

Mail: Uwe.Riedler@elmess.de

Telefon: +49 581908362

Telefax: +49 581908344

<http://www.elmess.de>

ELMESS Thermosystemtechnik GmbH
Nordallee 1
29525 Uelzen / Germany

Geschäftsführer: Christer Fredriksson

Kommanditgesellschaft, Uelzen HRB 212347 AG Lüneburg UST-ID-Nr.: DE124899586

1 Introduction

This Manufacturer's Standard covers Electric Immersion Heater (EIH) Element Support Plates to be bolted to flanges of pressure vessels in accordance with ASME BPVC Section VIII, Division 1. This Manufacturer's Standard is in full compliance with Paragraphs UG-5, UG-6 and UG-11(d).

We hereby certify that ELMESS EIH Element Support Plates are safe for the use under static internal pressure loads within the pressure-temperature ratings listed here. It is the user's responsibility to ensure that any other loads are considered separately in the design of the pressure equipment. The pressure equipment design lies within the responsibility of the manufacturer of the complete pressure equipment, see ASME BPVC Section VIII, Division 1, Paragraph U-2(b).

By issuance and publication of this Manufacturer's Standard ELMESS Thermosystemtechnik GmbH certifies that it meets the ASME BPVC paragraphs referenced. By marking the EIH Element Support Plates in accordance with this Manufacturer's Standard we certify that they are in full compliance with this Manufacturer's Standard and the referenced ASME BPVC requirements, as related to the manufacturing operations, welding, tests, examinations and marking performed by ELMESS Thermosystemtechnik GmbH. We have reviewed supplied certificates, documentation, material and subcontracted services to the best of our knowledge and belief and accepted them when related to our EIH Element Support Plates as per this Manufacturer's Standard. We hereby certify that all welding has been performed in accordance with qualified procedures and by welders certified in accordance with ASME BPVC Section IX.

This Manufacturer's Standard covers ELMESS EIH Element Support Plates made of the materials and dimensions as shown in Table 1.

Table 1:
Overview of the ELMESS EIH Element Support Plates covered in this Manufacturer's Standard

Class	Materials	NPS	Thickness (see Table 2 & 3)
150	SA-516 Gr.60, SA-105 with bolting SA-193 B7 – (CS)	4, 5, 6, 8, 12, 14, 16, 18, 20, 24, 28, 32, 36, 40, 48 10 (only Special CS) 12PH (only Standard CS)	Standard Special
300	SA-182 F316L, F316; F321, SA-240 316L, 316, 321 with bolting	4, 5, 6, 8 5H, 6DH (only Standard HA)	Standard Special
600	SA-193 B8M Class 2 – (HA)	4, 5, 6 8 (only Standard HA)	Standard Special

2 Marking

The ELMESS EIH Element Support Plates are marked either with the original manufacturer's marking or a coded marking traceable to the original material marking and the material test report.

In addition the ELMESS EIH Element Support Plates are marked with ELMESS tradename, EIH Element Support Plate designation, NPS, class and "Standard" or "Special".

3 Manufacturing

The ELMESS EIH Element Support Plates are manufactured using the manual Gas Tungsten Arc Welding (GTAW) Process with the use of filler material. The procedures are qualified and the welders are certified in accordance with the requirements of ASME BPVC Section IX. The related WPS and WPQ documentation can be supplied upon request.

4 Testing

Each ELMESS EIH Element Support Plate delivered as part of a complete pressure vessel is subject to a hydrostatic pressure test using water at a temperature of 10 to 30°C and a gauge pressure of 1.3 times the MAWP of the pressure vessel multiplied by the lowest stress ratio of the stress value S at test temperature to the stress value S at its design temperature or 1.43 times the MAWP of the pressure vessel whichever is greater. No visible leakage or deformation is permitted for the acceptance of the hydrostatic pressure test. By marking the ELMESS EIH Element Support Plates in accordance with this Manufacturer's Standard, we certify satisfactory test results for each of the ELMESS EIH Element Support Plates subject to a hydrostatic pressure test. Single ELMESS EIH Element Support Plates delivered without pressure vessel has to be tested by the user.

5 Material

The plates or forgings used for the ELMESS EIH Element Support Plates are certified to ASME BPVC Section II, Part A, SA-516 Gr. 60 or SA-105 or SA-182 F316L, F316, F321 or SA-240 316L, 316 or 321. The equivalent ASTM specifications are also permitted, when the Edition of the ASTM Specification is in the range as permitted by ASME BPVC Section II, Part A, Mandatory Appendix II and when it is ensured that the ASTM specification requirements are more stringent than or equivalent to the requirements of the ASME SA specification.

6 Pressure–Temperature Rating UG-11(d)

The pressure-temperature ratings for the ELMESS EIH Element Support Plates made from ferritic materials are given in Table 4 and those made from austenitic materials are given in Table 5. In the tables the maximum allowable pressures are listed for temperatures of 200°C and 350°C for the different Classes (150, 300 and 600) and Nominal Pipe Sizes.

The pressure rating for service at temperatures down to -29°C for ferritic materials and -196°C for austenitic materials shall be no greater than the rating shown in Tables 4 and 5. Some of the materials (e.g. carbon steels) may undergo a decrease in ductility when used at low temperatures to such an extent as to be unable to safely resist shock loading, sudden change of stress, or high stress concentration.

According to ASME BPVC Section VIII, Division 1, UG-20(f) ELMESS EIH Element Support Plates made of the covered ferritic materials are exempted from impact testing down to temperatures of -29°C if the thickness is smaller or equal to 100 mm. For ELMESS EIH Element Support Plates with thicknesses larger than 100 mm it is required to evaluate if those are exempted from impact testing per ASME BPVC Section VIII, Division 1, UCS-66. When the thickness of ELMESS EIH Element Support Plates made of the covered ferritic materials is larger than 100 mm it is the responsibility of the user to communicate to ELMESS prior to the time of purchase if impact testing is required or not. When UG-20(f) is applied it is necessary to ensure that all additional requirements (e.g. complete vessel hydro or pneumatically tested, design temperature $\leq 345^{\circ}\text{C}$, no shock and cyclic loading) defined in this paragraph are also fulfilled.

ELMESS EIH Element Support Plates made of the covered austenitic materials are exempted from impact testing down to temperatures of -196°C according to ASME BPVC Section VIII, Division 1, UHA-51(d) regarding base metal and heat affected zone. It shall be considered that the welding procedure qualification and welding consumables shall already be qualified with impact tests below temperatures of -104°C according to ASME BPVC Section VIII, Division 1, UHA-51(e) and (f). The other applicable requirements of UHA-51 shall be considered as well.

7 Basis for establishing the Pressure–Temperature Rating, UG-11(d)(11)(-c)

The pressure-temperature ratings are established based on the rules given in ASME BPVC Section VIII, Division 1, Mandatory Appendix 41 for the design of Electric Immersion Heater Element Support Plates. The selected element pattern, the minimum pitch, the hole diameters, the diameter of outer drilled element hole limit circle, radius to the center of the outermost drilled holes and other dimension for the different Nominal Pipe Sizes are summarized in Table 6.

In the establishment of the pressure-temperature ratings the allowable stress values and minimum yield strengths of ASME BPVC Section II, Part D, Table 1A and the modulus of elasticity given in ASME BPVC Section II, Part D, Table TM-1 are used. The values for the allowable stress as well as for the yield strength of the bolting materials are taken from ASME BPVC Section II, Part D, Table 3.

The dimensions of the EIH Element Support Plates (except thicknesses of the special plates) are taken from ASME B16.5-2020 (Pipe Flanges and Flanged Fittings NPS 1/2 through NPS 24 Metric/Inch Standard) and ASME B16.47-2020 (Large Diameter Steel Flanges NPS 26 through NPS 60 Metric/Inch Standard). Table 2 and Table 3 summarize the considered thicknesses of the center of the ELMESS EIH Element Support Plates for standard plate thicknesses according to ASME B16.5 / ASME B16.47 and special plate thicknesses.

The gasket dimensions are taken from ASME B16.21-2011. In the determination of the pressure-temperature ratings the gasket values $m = 3.5$ and $y = 20 \text{ MPa}$ are used. Lower gasket values are also covered.

For ferritic materials a corrosion allowance of 1 mm and for austenitic materials no corrosion allowance have been considered.

8 Documentation

ELMESS EIH Element Support Plates are supplied with the applicable drawings, specification sheet and the material test reports. Upon request the corresponding WPS, PQR and WPQ can be supplied.

Existing Documentation on Brazing and Welding Qualifications from ELMESS-Thermosystemtechnik GmbH & Co.KG are transferred to ELMESS Thermosystemtechnik GmbH.

Table 2: Thickness of the Center of the ELMESS EIH Element Support Plate for Ferritic Materials

Standard Sheet thickness according to ASME B16.5 / ASME B16.47				
Class		150	300	600
Nominal Pipe Size (NPS)	4	24.30 mm	32.20 mm	45.10 mm
	5	24.30 mm	35.40 mm	51.50 mm
	6	25.90 mm	37.00 mm	54.70 mm
	8	29.00 mm	41.70 mm	
	12PH	31.70 mm		

Special Sheet thickness							
Class		150		300		600	
		T = 200°C	T = 350°C	T = 200°C	T = 350°C	T = 200°C	T = 350°C
Nominal Pipe Size (NPS)	4			33.20 mm	33.55 mm	47.15 mm	46.25 mm
	5			36.35 mm	36.60 mm	54.80 mm	54.75 mm
	6			41.95 mm	42.30 mm	61.10 mm	61.60 mm
	8			49.95 mm	50.25 mm		
	10	-	42.00 mm				
	12	40.50 mm	38.05 mm				
	14	45.45 mm	42.90 mm				
	16	52.15 mm	49.00 mm				
	18	54.45 mm	50.25 mm				
	20	60.15 mm	55.35 mm				
	24	70.25 mm	64.20 mm				
	28	72.05 mm	63.50 mm				
	32	80.65 mm	70.85 mm				
	36	90.75 mm	79.55 mm				
	40	100.95 mm	88.55 mm				
	48	120.20 mm	105.00 mm				
48S	-	78.00 mm					

Table 3: Thickness of the Center of the ELMESS EIH Element Support Plate for Austenitic Materials

Standard Sheet thickness according to ASME B16.5 / ASME B16.47				
Class		150	300	600
Nominal Pipe Size (NPS)	4	24.30 mm	32.20 mm	45.10 mm
	5	24.30 mm	35.40 mm	51.50 mm
	6	25.90 mm	37.00 mm	54.70 mm
	8	29.00 mm	41.70 mm	62.60 mm
	5H		34.80 mm	
	6DH		36.60 mm	

Special Sheet thickness							
Class		150		300		600	
		T = 200°C	T = 350°C	T = 200°C	T = 350°C	T = 200°C	T = 350°C
Nominal Pipe Size (NPS)	4			35.90 mm	37.05 mm	51.30 mm	51.50 mm
	5			39.55 mm	40.50 mm	59.70 mm	61.25 mm
	6			45.90 mm	47.10 mm	67.35 mm	69.15 mm
	8			54.80 mm	56.05 mm		
	12	45.35 mm	43.30 mm				
	14	50.10 mm	47.85 mm				
	16	57.65 mm	54.80 mm				
	18	60.55 mm	56.15 mm				
	20	66.95 mm	61.90 mm				
	24	78.70 mm	71.10 mm				
	28	81.95 mm	71.45 mm				
	32	91.90 mm	79.85 mm				
	36	103.55 mm	89.75 mm				
	40	114.75 mm	99.30 mm				
48	137.05 mm	118.05 mm					

Table 4: Pressure-Temperature Rating for Ferritic Materials

Nominal Composition	Forgings	Plates
C-Si	SA-105	
C-Mn-Si		SA-516 Gr.60

Standard Sheet thickness according to ASME B16.5 / ASME B16.47							
Class		150		300		600	
Temperature		200°C	350°C	200°C	350°C	200°C	350°C
Nominal Pipe Size (NPS)	4	20.31 bar	15.70 bar	40.13 bar	33.72 bar	72.00 bar	72.00 bar
	5	7.94 bar	3.27 bar	41.28 bar	35.68 bar	65.56 bar	64.56 bar
	6	15.38 bar	11.70 bar	28.78 bar	24.10 bar	60.87 bar	51.08 bar
	8	16.29 bar	14.26 bar	24.32 bar	20.39 bar		
	12PH	8.00 bar					

Special Sheet thickness							
Class		150		300		600	
Temperature		200°C	350°C	200°C	350°C	200°C	350°C
Nominal Pipe Size (NPS)	4			45.00 bar	40.00 bar	90.00 bar	80.00 bar
	5			45.00 bar	40.00 bar	90.00 bar	80.00 bar
	6			45.00 bar	40.00 bar	90.00 bar	80.00 bar
	8			45.00 bar	40.00 bar		
	10	-	20.56 bar				
	12	15.00 bar	10.00 bar				
	14	15.00 bar	10.00 bar				
	16	15.00 bar	10.00 bar				
	18	15.00 bar	10.00 bar				
	20	15.00 bar	10.00 bar				
	24	15.00 bar	10.00 bar				
	28	15.00 bar	10.00 bar				
	32	15.00 bar	10.00 bar				
	36	15.00 bar	10.00 bar				
	40	15.00 bar	10.00 bar				
	48	15.00 bar	10.00 bar				
	48S	-	4.76 bar				

Table 5: Pressure-Temperature Rating for Austenitic Materials

Nominal Composition	Forgings	Plates
16Cr–12Ni–2Mo	SA-182 F316L	SA-240 316L
16Cr–12Ni–2Mo	SA-182 F316	SA-240 316
18Cr–10Ni–Ti	SA-182 F321	SA-240 321

Standard Sheet thickness according to ASME B16.5 / ASME B16.47							
Class		150		300		600	
Temperature		200°C	350°C	200°C	350°C	200°C	350°C
Nominal Pipe Size (NPS)	4	6.92 bar	-	24.21 bar	15.24 bar	52.86 bar	38.98 bar
	5	-	-	26.35 bar	19.69 bar	45.07 bar	32.37 bar
	6	6.70 bar	2.24 bar	16.77 bar	7.70 bar	34.18 bar	22.79 bar
	8	9.68 bar	6.29 bar	13.89 bar	6.41 bar	40.39 bar	-
	5H			-	25.00 bar		
	6DH			10.00 bar	-		

Special Sheet thickness							
Class		150		300		600	
Temperature		200°C	350°C	200°C	350°C	200°C	350°C
Nominal Pipe Size (NPS)	4			38.30 bar	32.60 bar	76.60 bar	65.20 bar
	5			38.30 bar	32.60 bar	76.60 bar	65.20 bar
	6			38.30 bar	32.60 bar	76.60 bar	65.20 bar
	8			38.30 bar	32.60 bar		
	12	13.80 bar	8.40 bar				
	14	13.80 bar	8.40 bar				
	16	13.80 bar	8.40 bar				
	18	13.80 bar	8.40 bar				
	20	13.80 bar	8.40 bar				
	24	13.80 bar	8.40 bar				
	28	13.80 bar	8.40 bar				
	32	13.80 bar	8.40 bar				
	36	13.80 bar	8.40 bar				
	40	13.80 bar	8.40 bar				
	48	13.80 bar	8.40 bar				

Table 6: Diameter of outer drilled element hole limit circle, radius to the center of the outermost drilled holes and other dimension for the different Nominal Pipe Sizes

Nominal Pipe Size	“Hüllkreis”	“Bündel-ø”	Inner diameter	diameter of holes	Type of Pattern	Pitch of element holes	radius to center of the outermost drilled holes
NPS / -	D _o / mm	l / mm	B / mm	d / mm		p / mm	r _o / mm
4	93.20	95.00	102.30	14.20	square	18.00	39.50
5	117.80	120.00	128.20	14.20	square	18.00	51.80
6	142.70	145.00	154.10	14.20	square	18.00	64.25
8	185.00	187.00	202.70	14.20	square	18.00	85.40
10	241.20	244.00	254.60	14.20	square	18.00	113.50
12	277.80	292.00	304.80	14.20	square	18.00	131.80
14	306.10	318.0	330.20	14.20	square	18.00	145.95
16	362.40	368.00	381.00	14.20	square	18.00	174.10
18	405.00	419.00	431.60	14.20	square	18.00	195.40
20	456.10	470.00	482.60	14.20	square	18.00	220.95
24	558.50	570.00	584.60	14.20	square	18.00	272.15
28	660.30	672.00	685.60	14.20	square	18.00	323.05
32	738.30	750.00	787.60	14.20	square	18.00	362.05
36	841.40	850.00	888.60	14.20	square	18.00	413.60
40	941.50	950.00	990.60	14.20	square	18.00	463.65
48	1138.90	1150.00	1193.60	14.20	square	18.00	562.35
5H	121.27	128.00	134.54	14.20	square	18.00	53.53
6DH	144.00	155.00	161.50	14.20	triangular	18.00	64.90
12PH	304.40	304.00	314.76	14.20	square	22.80	145.10

Remarks:

- D = type of pattern triangular
- P = deviating pitch of element holes
- H = deviating “Hüllkreis”
- S = Special Conditions

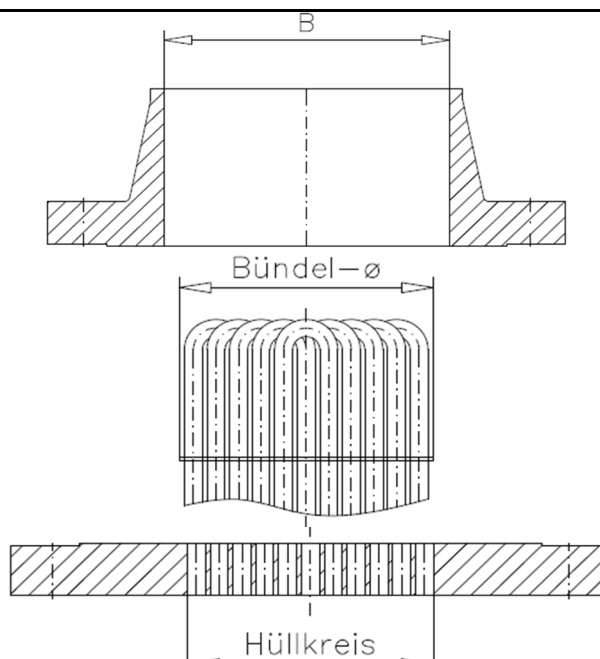

9 Annex: Calculations

Document Name	Pages
1 App41-2017-Class150_200°C_SA-516_Gr.60_Klingersil_Standard.pdf	32
2 App41-2017-Class150_350°C_SA-516_Gr.60_Klingersil_Standard.pdf	32
3 App41-2017-Class300_200°C_SA-516_Gr.60_Klingersil_Standard.pdf	32
4 App41-2017-Class300_350°C_SA-516_Gr.60_Klingersil_Standard.pdf	32
5 App41-2017-Class600_200°C_SA-516_Gr.60_Klingersil_Standard.pdf	24
6 App41-2017-Class600_350°C_SA-516_Gr.60_Klingersil_Standard.pdf	24
7 App41-2017-Class150_200°C_SA-516_Gr.60_Klingersil_Special.pdf	88
8 App41-2017-Class150_350°C_SA-516_Gr.60_Klingersil_Special.pdf	104
9 App41-2017-Class300_200°C_SA-516_Gr.60_Klingersil_Special.pdf	32
10 App41-2017-Class300_350°C_SA-516_Gr.60_Klingersil_Special.pdf	32
11 App41-2017-Class600_200°C_SA-516_Gr.60_Klingersil_Special.pdf	24
12 App41-2017-Class600_350°C_SA-516_Gr.60_Klingersil_Special.pdf	24
13 App41-2017-Class150_200°C_SA-182_F316L_Klingersil_Standard.pdf	32
14 App41-2017-Class150_350°C_SA-182_F316L_Klingersil_Standard.pdf	32
15 App41-2017-Class300_200°C_SA-182_F316L_Klingersil_Standard.pdf	32
16 App41-2017-Class300_350°C_SA-182_F316L_Klingersil_Standard.pdf	32
17 App41-2017-Class600_200°C_SA-182_F316L_Klingersil_Standard.pdf	32
18 App41-2017-Class600_350°C_SA-182_F316L_Klingersil_Standard.pdf	24
19 App41-2017-Class150_200°C_SA-182_F316L_Klingersil_Special.pdf	88
20 App41-2017-Class150_350°C_SA-182_F316L_Klingersil_Special.pdf	88
21 App41-2017-Class300_200°C_SA-182_F316L_Klingersil_Special.pdf	32
22 App41-2017-Class300_350°C_SA-182_F316L_Klingersil_Special.pdf	32
23 App41-2017-Class600_200°C_SA-182_F316L_Klingersil_Special.pdf	24
24 App41-2017-Class600_350°C_SA-182_F316L_Klingersil_Special.pdf	24
25 App41-2023-Class150_200°C_SA-516_Gr.60_Klingersil_Standard_NPS12PH.pdf	8
26 App41-2023-Class300_350°C_SA-182_F316L_Klingersil_Standard_NPS5H.pdf	8
27 App41-2023-Class300_200°C_SA-182_F316L_Klingersil_Standard_NPS6DH.pdf	8

Remarks:

- In all above mentioned Appendices “ASME Code Section VIII, Division 1, 2017 Edition, Appendix 41” is indicated, but the calculations are also in compliance with “ASME Code Section VIII, Division 1, 2023 Edition, Appendix 41”.
- Figures UHX-11.5.2-1 and UHX-11.5.2-2 of ASME Code Section VIII, Division 1 has been used until 2021 Edition. In the 2023 Edition the identical Figures are included in Figures 47-7-1 and 41-7-2 of Mandatory Appendix 41.
- Until 2021 Edition the EIH support plate flanged extension bolt load for the gasket seating condition (W) has been used in Step 8 of the Calculation. Since 2023 Edition the EIH support plate flanged extension bolt load for operating condition (W_{m1}) shall be used instead of the EIH support plate flanged extension bolt load for the gasket seating condition (W). W is always greater than W_{m1} therefore the pressure-temperature ratings given in this Manufacturer’s Standard are still valid.